

**HIGHLAND REDEVELOPMENT COMMISSION
STUDY SESSION MINUTES
TUESDAY, DECEMBER 15, 2020**

Members of the Highland Redevelopment Commission (“RC”, “Commission”) met in an electronically convened meeting using the Zoom platform on Tuesday, December 15, 2020. The meeting was convened as an electronic meeting pursuant to Governor Eric Holcomb’s Executive Order 20-04, 20-09 and 20-25 now extended through 31 December 2020 by his Order 20-49, allowing such meetings pursuant to IC 5-14-1.5-3.6 for the duration of the COVID-19 emergency. The Study Session was called to order at 7:00 p.m. by Commission President Cy Huerter.

Minutes were prepared by Kathy DeGuilio-Fox, Redevelopment Director and Recording Secretary.

Roll Call: Commissioners present included Jack Havlin, Cy Huerter, Robyn Radford, Renee Reinhart and Tony Washick. A quorum was established.

Additional Officials Present: Patrick Krull, School Town of Highland Liaison and non-voting member; Roger Sheeman, Council Liaison to the Redevelopment Commission; John P Reed, Redevelopment attorney, Abrahamson, Reed & Bilse; Ed Dabrowski, IT Consultant; and Kathy DeGuilio-Fox, Redevelopment Director.

Also Present: There were no additional attendees identified.

General Substance of the Discussion

- 1. Review of Plenary Business Meeting Agenda:** Ms. DeGuilio-Fox reviewed the agenda items that the Commissioners were to address during their plenary business meeting.
- 2. Parking Lot Project Highway & Kennedy – Update:** A brief overview was given of the construction activities since the last report. Director DeGuilio-Fox reported the completion of all major aspects of the project except the Depot. There are several items that remain unfinished on the Depot including the rooftop signage, fascia and soffits, and installation of doors and windows. NIPSCO electrical connection also remains to be completed along with the split rail fences. And, she mentioned that she had asked the contractor to block off the lot entrances, especially at night, so no one could drive in or out without lighting to provide safe pathways. Ms. DeGuilio-Fox reminded everyone that the contractor is being pushed to get as much completed as possible in spite of the weather turning colder. Ms. DeGuilio-Fox also mentioned the two artistic panels that have been mounted to the side of the Depot. She explained that one is an historical piece describing the site and nearby where the train depot stood decades ago. And, the other is a map of the locations of the public art murals throughout the downtown. She explained that Main Street is developing a self-guided mural tour. However, Ms. DeGuilio-Fox asked that everyone pay particular attention to the frame that was built by John Mouratides of the Public Works Department. She described the frame as awesome and encouraged everyone to take a look at it. Discussion ensued.
- 3. Downtown Streetlight Retrofit or Replacement – Update:** Director DeGuilio-Fox directed Commissioners’ attention to the new spreadsheet in their packets. She reminded them that new quotes had been received and the spreadsheet reflected the quotes based on a specific specification for the new fixtures. Ms. DeGuilio-Fox also advised that the installation quote had been added to the agenda due to the amount being \$16,200. This amount she explained is over the \$15,000.00 limit that she may approve without permission from the Commissioners. Discussion ensued. The Commissioners expressed satisfaction with the process, with the information they’d received and the in-depth

research that had been conducted to get the best price possible for the fixtures. Commissioners expressed interest in moving forward.

4. **Container Market – Discussion:** Ms. DeGuilio-Fox did not report any new information regarding this topic.
5. **Commercial Property Improvement Grants – Update and Discussion:** Director DeGuilio-Fox reminded the Commissioners they'd received a request from Bill Les for a completion extension on the façade improvement of his property located at 2708-2720 Highway Avenue and that the Resolution is in their packet for consideration.
6. **Highland Main Street – Restaurant Crawl:** Director DeGuilio-Fox reminded Commissioners that the December Restaurant Crawl was scheduled for Tuesday, December 29th and urged everyone to participate and support their local restaurants. The menu items for the Crawl were not provided in the commissioner's meeting packet because it was a little early in the month. Ms. DeGuilio-Fox shared what items she knew of.
7. **Redevelopment Commissioner Comments:** There were no additional comments from the Commissioners.

There being no further business the December 15, 2020 study session of the Highland Redevelopment Commission was adjourned at 7:13 P.M.

Respectfully submitted by Kathy DeGuilio-Fox, Recording Secretary.

**HIGHLAND REDEVELOPMENT COMMISSION
PLENARY MEETING MINUTES
TUESDAY, DECEMBER 15, 2020**

The Highland Redevelopment Commission ("Commission", "RC") met in an electronically convened meeting using the Zoom platform. The meeting was convened as an electronic meeting pursuant to Governor Eric Holcomb's Executive Order 20-04, 20-09 and 20-25 now extended through 31 December 2020 by his Order 20-49, allowing such meetings pursuant to IC 5-14-1.5-3.6 for the duration of the COVID-19 emergency. The Plenary Business Meeting was called to order at 7:13 p.m. by Commission President Cyril (Cy) Huerter.

Minutes were prepared by Kathy DeGuilio-Fox, Redevelopment Director and Recording Secretary.

Roll Call: Commissioners present included Jack Havlin, Cyril Huerter, Robyn Radford, Renee Reinhart and Tony Washick. A quorum was established.

Additional Officials Present: Patrick Krull, School Town of Highland liaison and no-voting member; Roger Sheeman, Town Council Liaison to the Redevelopment Commission; John Reed, Redevelopment attorney, Abrahamson, Reed & Bilse; Ed Dabrowski, IT Consultant and Kathy DeGuilio-Fox, Redevelopment Director.

Also Present: There were no additional attendees identified.

Minutes of the Previous Sessions: Commission President Cy Huerter called for a motion to approve minutes. Commissioner Jack Havlin moved to approve the minutes of the Study Session and Plenary Business meeting of November 24, 2020 and the minutes of the December 8, 2020 Study Session. Commissioner Renee Reinhart seconded the motion. There being no discussion, Commission President called for a roll call vote. Upon a roll call vote, the motion passed. The minutes of the Study Session and Plenary Business meeting of November 24, 2020 and the minutes of the December 8, 2020 Study Session were approved by a voice vote of five affirmatives and no negatives.

Special Orders: None

Public Comment: None

Communications: None

Unfinished Business and General Orders: None

New Business:

1. **Consideration of Resolution 2020-29: Resolution of the Highland Redevelopment Commission to Amend Resolution 2019-28 and Resolution 2020-24 and Provide a Completion Extension for a Commercial Property Façade Improvement Grant to Bill Les, Les Café Pancake House, of Property Located at 2708-2720 Highway Avenue.** Director DeGuilio-Fox reminded the Commissioners as to the reason for this resolution. Having duly considered Resolution 2020-29 and there being no further discussion, Commission President Cy Huerter called for a motion to approve. Commissioner Renee Reinhart made a motion to adopt and authorize Resolution 2020-29. Commissioner Robyn Radford seconded the motion. There was no further discussion. Commission President Cy Huerter called for a roll call vote. Upon a roll call vote the motion passed by a voice vote of five affirmatives and no negatives.

2. **Consideration of Resolution 2020-30: Resolution of the Highland Redevelopment Commission Accepting the Quote of Chicago Lightworks for the Downtown Street Lighting Replacement Project Being the Lowest Responsive and Responsible Quote in the Amount of Seventy-Eight Thousand Seven Hundred and Forty Dollars and 00/100 Cents (\$78,740.00).** There being no further discussion Commission President Cy Huerter called for a motion in consideration of Resolution 2020-30. Commissioner Jack Havlin moved to accept Resolution 2020-30. Commissioner Tony Washick seconded the motion. There was no further discussion. Commission President Huerter called for a roll call vote. Upon a roll call vote the motion to accept passed by a voice vote of five affirmatives and no negatives.
3. **Approval of Highland Redevelopment Commission Downtown Parking Lot Renovation Change Order Number 10:** Director DeGuilio-Fox explained that this change order is different from the others in that it provides a credit of \$60,578.23 to the project. In considering this credit and the total project adjustments are \$10,348.53. Commissioner Huerter asked if the commissioners had any questions regarding Change Order Numbers 10. Having discussed the change order and there being no further comments, Commissioner Huerter called for a motion to approve Change Order Number 10 as identified on the agenda. Commissioner Havlin made a motion to approve Change Order Number 10 as presented. Commissioner Radford seconded the motion. There being no further discussion Commission President Cy Huerter called for a roll call vote. Upon a roll call vote the motion passed by a voice vote of five affirmatives and no negatives.
4. **Consideration of Resolution 2020-31: Resolution of the Highland Redevelopment Commission Accepting the Quote of Midwestern Electric, Inc. for Installation of the Downtown Street Lighting Replacement Fixtures in the Amount of Sixteen Thousand Two Hundred Dollars and 00/100 Cents (\$16,200.00).** There being no discussion Commission President Cy Huerter called for a motion in consideration of Resolution 2020-31. Commissioner Havlin moved to accept Resolution 2020-31. Commissioner Reinhart seconded the motion. There was no further discussion. Commission President Huerter called for a roll call vote. Upon a roll call vote the motion to accept passed by a voice vote of five affirmatives and no negatives.
5. **Consideration of a Vacation Buy-Back Request form the Redevelopment Director.** Director DeGuilio-Fox explained that there were not enough days left in the year for her to take all of the allotted vacation time. Therefore, the only option was to “buy back” vacation time. There was no discussion on the topic. Commission President Cy Huerter called for a motion in consideration of the Director’s request. Commissioner Washick moved to accept the Director’s request to buy back vacation time. Commissioner Havlin seconded the motion. There being no further discussion Commission President Huerter called for a roll call vote. Upon a roll call vote the motion to accept passed by a voice vote of five affirmatives and no negatives.

Action to Pay Accounts Payable Vouchers: Commissioner Radford made a motion to pay accounts payable vouchers as filed on the pending accounts payable docket, covering the period November 27, 2020 through December 16, 2020 in the amount of \$224,673.11. Payroll expenses for Redevelopment employees were not included on this December docket. Commissioner Havlin seconded the motion to approve the Accounts Payable Vouchers. There being no further discussion Commission President Huerter called for a roll call vote. Upon a roll call vote the motion passed with five affirmatives and no negatives.

Vendors Accounts Payable Docket:

Redevelopment General Fund, \$6,906.23; Highland Economic Development, \$0.00; Redevelopment Capital Fund, \$36,934.49; Downtown Redevelopment District Allocation Area, \$177,965.41; Redevelopment Bond & Interest, \$0.00; CEDIT Economic Development Income Tax Fund, \$2,866.98 and Cardinal Campus Allocation Area, \$0. Total: \$239,264.10.

Business from the Commissioners: 1. Commission President Huerter asked if there was any business from the commissioners. Commissioner Huerter asked is we have another plan for the Bult Oil property. Ms. DeGuilio-Fox confirmed that the environmental covenant, approved by the Commissioners at their November meeting, has been recorded at the Lake County Recorder's office. In January the Commissioners may begin to negotiate a new selling price with an interested party. She suggested the Commissioners discuss this topic at their study session in January. 2. Commissioner Washick asked if there are any plans for the former Town Theatre property. Director DeGuilio-Fox advised that she has been talking with an interested Developer. However, they've asked that their name is not disclosed at this time. They are hoping to speak with other property owners in the vicinity soon and will know more once they have those conversations. 3. Commissioner Huerter asked if there is any additional information to share in regard to the gas station. Director DeGuilio-Fox reported that the conversation she and Ken Mika had with the Speedway representatives has moved them to make plans to demolish the existing structure on the Kennedy Avenue property and clean it up. 4. Commissioner Huerter asked about the Highland Plaza and the former Ultra property. Ms. DeGuilio-Fox reported that most inquiries are related to self-storage developments which the Town does not allow. She also mentioned that she is having conversations with a family-owned business in Illinois who is interested in the former Ultra store. However, an agreement has to be reached with DLC Management who currently owns the property before anything can come to the Town for consideration. 5. Commissioner Huerter also asked for an update regarding the former Tri-State Bus property on north Indianapolis Blvd. Director DeGuilio-Fox reported that the corporation who had interest in the property has withdrawn their offer to purchase due to a lack of interest by the Town. If there is more information in the future it will be reported.

Next Meeting: President Huerter advised that the next Study Session is scheduled for Tuesday, January 12, 2021 and will convene at 7:00 PM. The next Plenary Business Meeting is scheduled for Tuesday, January 26, 2021 immediately following the study session. A Study Session will reconvene following the public meeting, if deemed necessary. The next meeting of the Highland Main Street is scheduled to convene on Thursday, January 7, 2021 at 6:30 p.m. Due to the Executive Orders issued by Governor Holcomb in response to the COVID-19 pandemic, a decision will be made as to whether meetings will be convened electronically or if the opening of the Town Hall will allow for a public meeting to be held in Council Chambers.

Adjournment: There being no further business, Commission President Huerter called for a motion to adjourn. Commissioner Havlin made a motion to adjourn. Commissioner Washick seconded the motion. Upon a roll call vote the motion passed by a voice vote of five affirmatives and no negatives. The December 15, 2020 public meeting of the Highland Redevelopment Commission was adjourned at 7:38 p.m.

Respectfully submitted by Kathy DeGuilio-Fox, Recording Secretary

Resolution No. 2020-29

A RESOLUTION OF THE HIGHLAND REDEVELOPMENT COMMISSION TO AMEND RESOLUTION 2019-28 AND RESOLUTION 2020-24 AND PROVIDE A COMPLETION EXTENSION FOR A COMMERCIAL PROPERTY FAÇADE IMPROVEMENT GRANT TO BILL LES, LES CAFÉ PANCAKE HOUSE, OF PROPERTY LOCATED AT 2708-2720 HIGHWAY AVENUE

WHEREAS, the Highland Redevelopment Commission (the "Commission"), governing body of the Town of Highland Department of Redevelopment (the "Department"), and the Redevelopment Area of the Town of Highland, Indiana (the "Redevelopment District"), exists and operates under the provisions of the Redevelopment of Cities and Towns Act 1953 which has been codified in IC 36-7-14, as amended from time to time (the "Act"); and

WHEREAS, the Commission on May 28, 1997, adopted Resolution No. 1997-01 declaring the Highland Redevelopment Area to be an area in need of redevelopment within the meaning of the Act; and

WHEREAS, Resolution No. 1997-01 confirmed by the Commission with the adoption of Resolution No. 1997-02 on July 8, 1997; and

WHEREAS, subsequent Resolutions, No. 2003-01, No. 2005-11, No. 2006-10, No. 2007-08 and No. 2008-09 confirmed expansion of the Redevelopment Area; and

WHEREAS, the Commission accepted the 2007 Comprehensive Plan for the Highland Redevelopment Area on March 14, 2007; and

WHEREAS, the Commission has prepared, developed and approved the Supplement to the Highland Municipal Code, Section 214.180: RD-Redevelopment District (Architectural and Design Standards and Guidelines for the Redevelopment Area) and

WHEREAS, the Commission from time to time may develop a program to improve the downtown; and

WHEREAS, the Commission through its 2016 budget approved the Façade Improvement Grant Program which is intended to provide financial assistance for significant exterior building façade improvement in the Highland Downtown Redevelopment Area; and

WHEREAS, the goal of the program is to attract retail growth, additional business traffic, and catalyze investment through improved aesthetics; and

WHEREAS, The Les Café Pancake House, by and through Bill Les, applied for a grant totaling \$79,000, of which a not to exceed 30%, or \$23,700.00 would be reimbursed upon completion of the work with approved receipts; and

WHEREAS, the original grant application was given approval on August 19, 2019 by Resolution No. 2019-28 for a maximum award of \$23,700.00; and

WHEREAS, on July 28, 2020 approval was granted through adoption of Resolution 2020-24 to extend the completion deadline to December 5, 2020 due to an inability to complete the approved improvements within the one (1) year timeline allowed by the application process; and

WHEREAS, the Redevelopment Commission recognizes that accessing materials and mobilizing construction crews was affected by Executive Order 20-02, and all COVID-19 related subsequent Executive Orders, as issued by Indiana Governor Eric Holcomb addressing the public health emergency created by the COVID-19 pandemic; and

WHEREAS, the grantee, The Les Café Pancake House, is seeking consideration to amend Resolution 2020-24 by and through Resolution 2020-29 and requests to extend the completion deadline of said Commercial Property Façade Improvement Grant project to May 1, 2021; and

All property taxes must be paid and up to date and there shall be no liens against the property;

NOW, THEREFORE, BE IT RESOLVED by the Highland Redevelopment Commission as follows:

1. That the Commission finds and determines it will be of public utility and benefit to approve the completion extension requested by The Les Café Pancake House for a Commercial Property Façade Improvement Grant for property located at 2708-2720 Highway Avenue.
2. The original total project cost applied for was \$79,000.00 as designated by the contractors work estimates submitted as supporting documentation to the application and remains unchanged.
3. That the Commission has approved by and through Resolution 2019-28 and will provide an up to and not to exceed reimbursement of \$23,700.00 of the estimated project costs, based upon the total project cost of \$79,000.00 remains unchanged.
4. That all reimbursements will be made upon delivery of receipts and proof of work completed, to the Highland Redevelopment Commission, of approved receipts for work performed, and proof that all property taxes are paid and up-to-date and no liens have been filed on the property remains unchanged.
5. That this Resolution shall be in full force and effect after its adoption by the Commission.

ADOPTED AND APPROVED by the Highland Redevelopment Commission, Lake County, Indiana this 15th day of December, 2020 having passed by a vote of 5 in favor and 0 opposed.

Highland Redevelopment Commission

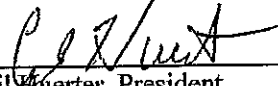
By: 
Cyril Huarter, President

ATTEST:

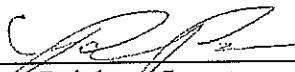
By: 
Renee Reinhart, Secretary

By: 
Kathy DeGuilio-Fox
Redevelopment Director

RESOLUTION 2020-30

**A RESOLUTION OF THE HIGHLAND REDEVELOPMENT COMMISSION
ACCEPTING THE QUOTE OF CHICAGO LIGHTWORKS FOR THE
DOWNTOWN STREET LIGHTING REPLACEMENT PROJECT
BEING THE LOWEST RESPONSIVE AND RESPONSIBLE QUOTE IN THE AMOUNT OF
SEVENTY-EIGHT THOUSAND SEVEN HUNDRED AND FORTY DOLLARS
AND 00/100 CENTS (\$78,740.00)**

Whereas, The Redevelopment Commission of the Town of Highland, Indiana (“The Redevelopment Commission”) is authorized to undertake redevelopment activities under IC 36-7-14 (the “Act”) and more specifically Section 39 for which public money may be spent and private property may be acquired; and

Whereas, Redevelopment activities include performing all acts incident to the statutory powers and duties of a Redevelopment Commission; and

Whereas, The Redevelopment Commission is authorized to negotiate and enter into contracts pursuant to the Act; and

Whereas, initial quotes from potential venders were rejected by the Highland Redevelopment Commission at their regularly scheduled plenary business meeting convened on Tuesday, November 24, 2020 due to the incomparable nature of the quotes as allowed by IC 5-22-10, Special Purchasing and Highland Municipal Code 3.05.065, and

Whereas, an Itemized Quote Schedule with acceptable product line and product specifications was provided to potential providers; and

Whereas, specification related to existing luminaires, key specifications of the proposed LED Luminaires and acceptable product lines information has been included in the Itemized Quote Schedule as determined by the Redevelopment Commission; and

Whereas, the following quotes were received at, or before, 2:00 p.m. on December 8, 2020:

	<u>Bidder</u>	<u>Base Bid</u>
1.	Chicago Lightworks	\$ 78,740.00
2.	Holophane Lighting	\$ 99,200.00
3.	Holophane Lighting	\$102,920.00
4.	EMCOR Hyre Electric Co. of Indiana, Inc	\$104,160.00

Whereas, the Director of Redevelopment and Redevelopment Commission has reviewed the quotes and determined that the bid of Chicago Lightworks, in the amount of Seventy-Eight Thousand Seven Hundred and Forty Dollars and 00/100 Cents (\$78,740.00), to be the lowest responsive and responsible quote; and

Whereas, there are sufficient and available appropriations balances on hand to support the payments under the agreement, pursuant to IC 36-7-14 (the "Act") and more specifically Section 39; and

Whereas, the Town of Highland, through its Redevelopment Commission, now desires to accept the recommendation of the Redevelopment Director and award a contract to Chicago Lightworks for the Downtown Street Lighting Replacement Project.

NOW, THEREFORE, BE IT RESOLVED by the Highland Redevelopment Commission of the Town of Highland, Lake County, Indiana as follows:

1. The prefatory statements set forth above are incorporated herein as if set forth at length.
2. That it is in the best interest of the Town to accept the quote from Chicago Lightworks in the amount of \$78,740.00.
3. Further, the Redevelopment Director is hereby authorized to execute the agreement and all documents necessary to implement the project.
4. This resolution shall be in full force and effect after its passage and adoption by the Redevelopment Commission.

DULY PASSED AND RESOLVED by the Redevelopment Commission of the Town of Highland, Lake County, Indiana, this 15th day of December, 2020 having passed by a vote of 5 in favor and 0 opposed.

REDEVELOPMENT COMMISSION of the
TOWN OF HIGHLAND, INDIANA

By: Cyril Huerter
Cyril Huerter, President

ATTEST:

By: Renee Reinhart
Renee Reinhart, Secretary
Town of Highland, Indiana Redevelopment Commission

December 16, 2020
Dated

By: Kathy DeGuilio-Fox
Kathy DeGuilio-Fox, Redevelopment Director
Town of Highland Department of Redevelopment

December 16, 2020
Dated

Resolution 2020-30_Adopted 12-15-2020

QUOTE FORM

TOWN OF HIGHLAND, INDIANA
 HIGHLAND REDEVELOPMENT COMMISSION
 DOWNTOWN STREET LIGHTING REPLACEMENT

The work for which quotes are to be submitted consists of furnishing and delivering one hundred twenty-four (124) dome-style LED pendant luminaires to the Town of Highland, as described herein. Installation is not to be included in this quote, as the luminaires will be installed separately by others.

The existing luminaires are 24-inch diameter Lumec DMS20 "Domus" style, 175 Watt metal halide, 240 Volt, with Type 3 distribution, clear flat glass lens and black finish. It is the intent of this specification for the proposed LED luminaires to be of similar visual appearance and produce similar light levels as the existing metal halide fixtures, but with significantly less consumption of electricity. Key specifications of the proposed LED luminaires are as follows:

1. Housing Design: Dome-style pendant with proposed fixture diameter +/- 3.5 inches of existing fixture (i.e. diameter in the range of 20.5-inch to 27.5-inch, inclusive), black finish and clear flat glass lens. Fixture must be capable of being mechanically secured to the 2-inch I.D. pendant tenon extending down from the existing welded arm adaptor. Hardware to be stainless steel.
2. LED Characteristics: Initial light output of at least 7,100 lumens, color temperature of 4000K, calculated L70 life >100,000 hours, and Type 3 optical distribution.
3. Electrical Requirements: System wattage (LED + Driver) in the range of 65 to 75 watts, voltage of 240V, and Driver current of 700 mA. Dimming-capable driver is acceptable, but not required; minimum 7,100 lumens to be provided at factory setpoint.
4. Warranty: Manufacturer's standard 5-year limited warranty covering defects in material and workmanship for fixture finish and LED components. Cracking, peeling, blistering, excessive fading and corrosion would each constitute fixture finish failure. Failure of 10% or more of the total number of LEDs in the light engine would constitute LED component failure.

Acceptable product lines are Domus DMS50 LED Pendant (Lumec by Signify), Domia SY21P1 LED Pendant (Cyclone Lighting), or Domia CY55P1B LED Pendant (Cyclone Lighting).

Please provide a quote for the Highland Redevelopment Commission's "Downtown Street Lighting Replacement" using the itemized quote schedule listed below. A copy of the manufacturer's product brochure and standard warranty need to be attached to this quote for the manufacturer/model of LED fixture proposed.

ITEMIZED QUOTE SCHEDULE

Item	Brief Description	Quantity	Units	Unit Price	Total Quote Amount
1	Dome-Style LED Pendant Luminaire (20.5"-26.5" Dia., Approx. 65-75 Watts, Min. 7,100 Lumens, 4000K, Type 3 Distribution, Flat Glass Lens, 240V, Black Finish)	124	EA	\$635.00	\$78,740.00
MANUFACTURER & MODEL NUMBER OF LUMINAIRE QUOTED		[DMS50-046]-65W32LED4K-T-LE3F-240-DMG-[MAR-012]-BKTX			

In submitting this quote, it is understood that the Owner reserves the right to reject any and all quotes. It is agreed that this quote may not be withdrawn for a period of 21 days from the opening thereof.

Delivery Time: If this Quote is accepted by the Owner, the Undersigned agrees to deliver the 124 luminaires to the Town of Highland, or its designated installation Contractor, within 120 calendar days. Exact delivery address to be coordinated with Town of Highland prior to product shipment.

Chicago Lightworks

(Name of Company Submitting Quote)

By:

Rob Robinson

(Signature of Authorized Representative)

Outdoor Sales Lead

(Title of Authorized Representative)

505 WARRENVILLE RD #101

(Business Address)

LISLE, IL 60532

Date:

12/8/2020

ACCEPTED:

REDEVELOPMENT COMMISSION of the
TOWN OF HIGHLAND, INDIANA

Cyril Huerter, President

ATTEST:

Renee Reinhart, Secretary

Kathy DeGuilio-Fox

Kathy DeGuilio-Fox, Redevelopment Director

December 16, 2020

Date

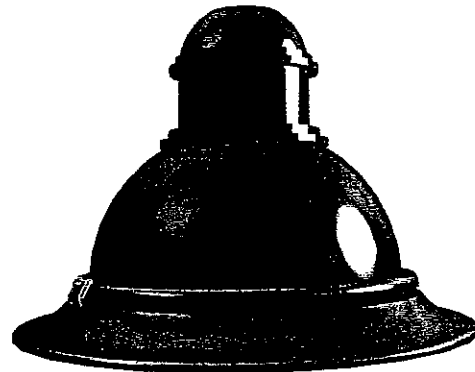
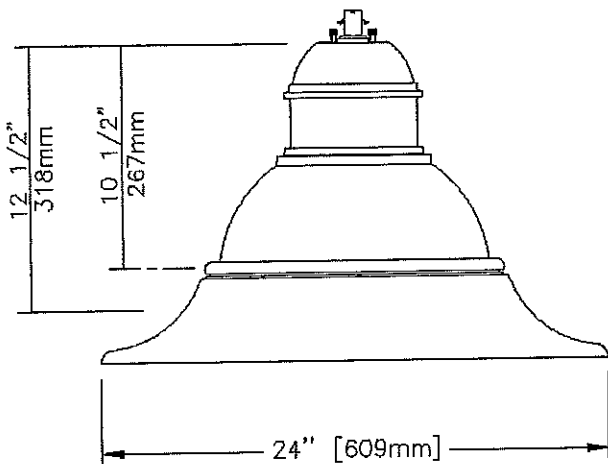

EPA: 1.42 sq ft / weight: 42 lb (19.1 kg)
Note: 3D image may not represent color or option selected.
Logos above include link, click to access.

Qty	124	Luminaire	[DMS50-046]-65W32LED4K-T-LE3F-240-[MAR-012]-BKTX
-----	-----	-----------	--

Description of Components:

Housing: In a round shape, this housing is made of die cast A380 aluminum, c/w a watertight grommet, mechanically assembled to the bracket with four bolts 5/16 18 UNC. This suspension system permits for a full rotation of the luminaire in 90 degree increments.

Access-Mechanism: A die cast A360 aluminum technical ring with latch, hinge and a cast in decorative skirt. The mechanism shall offer tool free access to the inside of the luminaire. An embedded memory retentive gasket shall ensure weatherproofing.

Light Engine: LEDgine composed of 5 main components: Heat Sink / Lens / LED Module / Optical System / Driver
Electrical components are RoHS compliant.

Heat Sink: Made of cast aluminum optimising the LEDs efficiency and life. Product does not use any cooling device with moving parts (only passive cooling device).

Lens: Made of soda-lime clear tempered flat glass lens, mechanically assembled and sealed onto the lower part of the heat sink.

Lamp: LED type Philips Lumileds LUXEON T. Composed of 32 high performance white LEDs. Color temperature as per ANSI/NEMA bin Neutral White, 4000 Kelvin nominal (3985K +/- 275K or 3710K to 4260K), CRI 70 Min. 75 Typical.

[DMS50-046]-65W32LED4K-LE3F= 700mA, 8560 lumens output +/- 5%, Lm/W 132.

LED Module: LED type Philips Lumileds LUXEON T. Composed of 32 high-performance white LEDs. Color temperature as per ANSI/NEMA bin Neutral White, 4000 Kelvin nominal (3985K +/- 275K or 3710K to 4260K), CRI 70 Min. 75 Typical.

Optical System: (LE3F), IES type III (asymmetrical). Composed of high-performance optical grade PMMA acrylic refractor lenses to achieve desired distribution optimized to get maximum spacing, target lumens and a superior lighting uniformity. Optical system is rated IP66. Performance shall be tested per LM-63, LM-79 and TM-15 (IESNA) certifying its photometric performance. Street side indicated. 0% uplight and U0 per IESNA TM-15.

Driver: High power factor of 90% minimum. Electronic driver, operating range 50/60 Hz **Auto adjusting universal voltage input from 120 to 277 VAC rated for both application line to line or line to neutral, Class 1**, , THD of 20% max. Maximum ambient operating temperature from 40F(40C) to 130F(55C) degrees. Driver comes with dimming compatible 0 10 volts.

The current supplying the LEDs will be reduced by the driver if the driver experiences internal overheating as a protection to the LEDs and the electrical components. Output is protected from short circuits, voltage overload and current overload. Automatic recovery after correction. Standard built in driver surge protection of 2.5kV (min).

Surge Protector: Surge protector tested in accordance with ANSI/IEEE C62.45 per ANSI/IEEE C62.41.2 Scenario I Category C High Exposure 10kV/10kA waveforms for Line-Ground, Line-Neutral and Neutral-Ground, and in accordance with U.S. DOE (Department of Energy) MSSLC (Municipal Solid-State Street Lighting Consortium) model specification for LED roadway luminaires electrical immunity requirements for High Test Level 10kV / 10kA.

Adaptor: (MAR-012) Fixture complete with quick disconnect lever connectors, male and female connectors.

Miscellaneous

Description of Components:

Wiring: Gauge (#14) TEW/AWM 1015 or 1230 wires, 6" (152mm) minimum exceeding from luminaire.

Hardware: All exposed screws shall be complete with Ceramic primer-seal basecoat to reduce seizing of the parts and offers a high resistance to corrosion. All seals and sealing devices are made and/or lined with EPDM and/or silicone and/or rubber.

Finish: Color to be **black textured RAL9005TX (BKTX)** and in accordance with the AAMA 2603 standard. Application of polyester powder coat paint (4 mils/100 microns) with ± 1 mils/24 microns of tolerance. The Thermosetting resins provides a discoloration resistant finish in accordance with the ASTM D2244 standard, as well as luster retention in keeping with the ASTM D523 standard and humidity proof in accordance with the ASTM D2247 standard.

The surface treatment achieves a minimum of 2000 hours for salt spray resistant finish in accordance with testing performed and per ASTM B117 standard.

LED products manufacturing standard: The electronic components sensitive to electrostatic discharge (ESD) such as light emitting diodes (LEDs) are assembled in compliance with IEC61340-5-1 and ANSI/ESD S20.20 standards so as to eliminate ESD events that could decrease the useful life of the product.

Quality Control: The manufacturer must provide a written confirmation of its ISO 9001-2008 and ISO 14001-2004 International Quality Standards Certification.

Vibration Resistance: The DMS50 meets the **ANSI C136.31, 2010**, American National Standard for Roadway Luminaire Vibration specifications for Bridge/overpass applications. (Tested for 3G over 100 000 cycles)

Web site information details: / [cULus Certification](#)

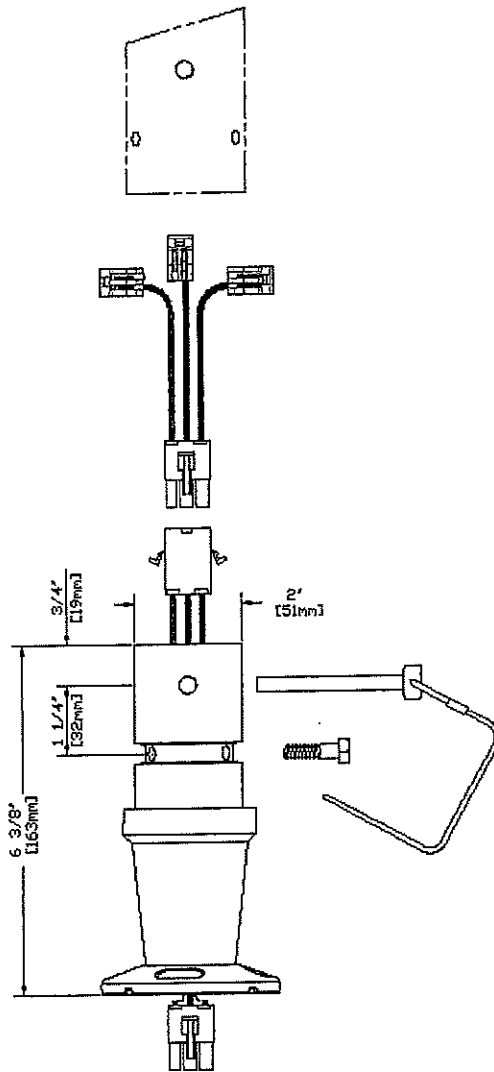

MAR-012



Warranty

Outdoor

Professional Luminaires

Limited Warranty: Outdoor Professional Luminaires

Signify North America Corporation ("Signify") warrants to the original purchaser ("Purchaser") that the Signify branded outdoor professional luminaires identified on Schedule 1 ("Products") will be free from defects in material and workmanship which cause the Product to fail to operate in accordance with the performance specifications set forth in documentation published for or provided with the Product ("Specifications") for the applicable period and subject to the additional terms and conditions set forth on Schedule 1 from the date of purchase (as set forth in the applicable invoice) ("Warranty Period").

Unless otherwise noted on Schedule 1, Signify warrants that any standard finish on a Product will be free of cracking, peeling, excessive fading, and corrosion defects during the applicable Warranty Period. To the extent that an authorized Signify distributor is the Purchaser of the Products, such distributor may transfer this limited warranty to subsequent purchasers of the Products, provided that such Products are resold in new condition and in their original packaging. For LED Products, the Product shall be considered defective only if 10% or more of the LED components fail for such Product.

Photocells (standard issue NEMA and button type), occupancy sensors, low voltage indicators, fuses, surge suppressors and other third party accessories that are not manufactured by Signify are excluded from this warranty, but may be covered by a third party manufacturer. Such third party manufacturer shall be solely responsible for the costs related to any claims associated with any such accessories. Extended life photocells carry a 10-year limited warranty from the third party manufacturer. Emergency battery packs and polycarbonate lenses (used on vandal resistant products or as vandal resistant covers or options) have a Warranty Period of 1 year.

If any Product covered by this limited warranty is returned by Purchaser in accordance with Signify Terms and Conditions of Sale (available at www.Signify.com/warranties) within the Warranty Period, and Signify determines to its satisfaction that such Product failed to satisfy this warranty, Signify will, at its option, repair or replace the Product or the defective part thereof, or reimburse Purchaser for the purchase price, subject to the terms and conditions set forth herein. For purposes of clarity, "repair or replace the Product or the defective part thereof" does not include any removal or reinstallation costs or expenses, including, without limitation, any labor costs or expenses, shipping costs to return non-conforming Products or any damages that may occur during the return of Product to Signify. If Signify chooses to replace the Product and is not able to do so because it has been discontinued or is not available, Signify may replace it with a comparable product. Signify reserves the right to use new, reconditioned, refurbished, repaired or remanufactured products or parts in the repair or replacement of any Product covered by this limited warranty.

Warranty Outdoor Professional Luminaires

This limited warranty is subject to these additional conditions:

- The Products have been properly handled, stored, wired, transported, installed, operated and maintained in accordance with the applicable Specifications.
- A Signify representative will have access to the failed Products and the fixtures used to operate them. If the fixture or other parts become suspect, the representative shall have the right to invite other manufacturers' representatives to evaluate the lighting system components.
- The Product has been purchased directly from an authorized Signify distributor/dealer for use in regions that are within the jurisdiction of the United States or Canada.
- Purchase receipt for the Product is available for inspection by Signify.

This limited warranty does not apply to damage or failure to perform arising as a result of any acts of God or from any abuse, misuse, abnormal use, improper power supply, powers surges or fluctuations, corrosive environments, neglect, exposure or any use or installation in violation of the instructions or restrictions prescribed by Signify or any applicable standard or code, including those contained in the latest National Electrical Code, Standards for Safety of Underwriters Laboratory, Inc. (UL), the American National Standards Institute (ANSI), or, in Canada, the Canadian Standards Association (CSA). No agent, distributor or dealer is authorized to change, modify or extend the terms of this limited warranty on behalf of Signify. THIS LIMITED WARRANTY IS VOID IF THE PRODUCT IS NOT USED FOR THE PURPOSE FOR WHICH IT IS DESIGNED OR IF ANY REPAIRS OR ALTERATIONS ARE MADE BY ANY PERSON NOT AUTHORIZED BY SIGNIFY IN WRITING.

THIS LIMITED WARRANTY IS THE ONLY WARRANTY GIVEN BY SIGNIFY WITH RESPECT TO THE PRODUCTS AND THE SOLE REMEDY FOR ANY AND ALL CLAIMS, IN CONTRACT, IN TORT OR OTHERWISE ARISING FROM THE FAILURE OF PRODUCT AND IS GIVEN IN LIEU OF ALL OTHER WARRANTIES, EXPRESS OR IMPLIED, INCLUDING, BUT NOT LIMITED TO, WARRANTIES OF MERCHANTABILITY OR FITNESS FOR A PARTICULAR PURPOSE, WHICH WARRANTIES ARE HEREBY EXPRESSLY DISCLAIMED.

PURCHASER'S EXCLUSIVE REMEDY FOR ANY NONCONFORMITY OR DEFECT IN ANY PRODUCT SHALL BE ONLY AS EXPLICITLY SET FORTH HEREIN. UNDER NO CIRCUMSTANCES SHALL SIGNIFY' AGGREGATE LIABILITY ARISING OUT OF OR IN CONNECTION WITH A DEFECTIVE PRODUCT, IN CONTRACT, TORT OR OTHERWISE, EXCEED THE PURCHASE PRICE OF THE PRODUCT TO WHICH SUCH LIABILITY RELATES. IN NO EVENT SHALL SIGNIFY BE LIABLE FOR SPECIAL, INCIDENTAL, CONSEQUENTIAL, INDIRECT OR COMPENSATORY DAMAGES, INCLUDING, WITHOUT LIMITATION, DAMAGES RESULTING FROM LOSS OF USE, PROFITS, BUSINESS OR GOODWILL EVEN IF SIGNIFY WAS ADVISED OF OR WAS OTHERWISE AWARE OF THE POSSIBILITY OF SUCH DAMAGES.

Special conditions related to all solar Products:

- The Warranty Period for solar panels is 5 years and for batteries is 3 years.
- Batteries are fully charged when shipped to the Purchaser or installation site. The batteries must be installed and operational no later than 2 months from the day of shipment. If stored beyond such time period, the Purchaser is responsible for recharging the batteries according to battery manufacturer's instructions at 2 months and every two month thereafter. This limited warranty does not cover batteries if: (i) program has been altered without Signify authorization, (ii) systems that have not been designed or sized according to Signify standard design practices, or (iii) systems where Signify has conveyed as per specific sales orders, that battery life and other components will be less than the Warranty Period.
- Improper installation includes but is not limited to improper placement, orientation, tilt and/or shading conditions not considered in the energy profile and design conditions.

This limited warranty is effective for the purchases of the Product on or after the effective date set forth herein and is in consideration of and is expressly subject to and conditioned by the terms set forth herein. Signify reserves the right to modify this warranty from time to time and any modifications shall be effective for all orders placed on or after the effective date of such revised warranty.

Warranty Outdoor Professional Luminaires

Schedule 1: All Signify outdoor professional luminaires not otherwise described below shall have a warranty period of 1 year.

Signify outdoor professional luminaires product lines	LED	Non-LED	Special Conditions
Stonco/Keene	5 years	1 year	Standard finishes: 5 year warranty on finish for LED products and 1 year warranty on all other products. Custom finishes: 1 year warranty on the finish on all products. Optical color filters made from glass or polymeric materials such as acrylic, polyester or polycarbonate have a Warranty Period of 1 year from original shipment date. Color fading of lens material of any kind is not covered under this limited warranty.
Gardco	5 years	1 year	Standard finishes: 5 year warranty on finish for LED products and 1 year warranty on all other products. Custom finishes: 1 year warranty on finish. Optical color filters made from glass or polymeric materials such as acrylic, polyester or polycarbonate have a Warranty Period of 1 year from the date of original.
	10 years	N/A	DuraForm Small (FLDS), Medium (FLDM), and Large (FLDL) LED Floodlighting
Urban: Hadco & Lumec	5 years	1 year	Standard finishes: 5 year warranty on finish for LED products and 1 year warranty on all other products. Custom finishes: 1 year warranty on finish.
Landscape: Hadco	5 years	1 years	Landscape Products: Warranty Period for all grade mounted composite luminaires, copper luminaires and transformers is 10 years. Lifetime warranty offered on the finish for all cast bronze and stainless steel housing.
Roadway: Lumec	10 years	1 years	Standard finishes: 10 year warranty on the finish for LED products and 1 year warranty on the finish for all other products. Custom finishes: 1 year warranty on finish. Roadway Security Light (RSLs, RSLM): 5 year warranty for fixture and finish
Phillips	5 years	N/A	Standard finishes: 5 year warranty on finish.
Color Kinetics (all products)	5 years	5 years	Warranty Period for products purchased or used for touring and / or rental purposes is three (3) years. Custom finishes: 1 year warranty on finish.
Color Kinetics (Vaya white UL)	5 years	5 years	Warranty Period for products purchased or used for touring and / or rental purposes is one (1) year. Custom finishes: 1 year warranty on finish.
Color Kinetics (all other Vaya products)	3 years	3 years	Warranty Period for products purchased or used for touring and / or rental purposes is one (1) year. Custom finishes: 1 year warranty on finish.

Poles & Brackets**	Aluminum Structural	Aluminum Std. Finish	Steel Structural	Steel Std. Finish	Special Conditions
Lumec (USA)	3 years	5 years	1 year	1 year	Custom finishes: 1 year warranty (unless otherwise noted).
Hadco	3 years	5 years	1 year	1 year	
Gardco (USA)	1 year	1 year	1 year	1 year	
High Mast (Poles & raising/lower devices)	1 year	1 year	1 year	1 year	

** Poles not manufactured by Signify will reflect the warranty of the original manufacturer (consult with factory on specifics).

** Consult factory for product intended to be installed in coastal conditions (within 5km/3mi from seashore).



© 2020 Signify Holding. All rights reserved. The information provided herein is subject to change, without notice. Signify does not give any representation or warranty as to the accuracy or completeness of the information included herein and shall not be liable for any action in reliance thereon. The information presented in this document is not intended as any commercial offer and does not form part of any quotation or contract, unless otherwise agreed by Signify.

Signify North America Corporation
200 Franklin Square Drive,
Somerset, NJ 08873
Telephone 855-486-2216

Signify Canada Ltd.
281 Hillmount Road,
Markham, ON, Canada L6C 2S3
Telephone 800-668-9008

All trademarks are owned by Signify Holding or their respective owners.

RESOLUTION 2020-31

**A RESOLUTION OF THE HIGHLAND REDEVELOPMENT COMMISSION
ACCEPTING THE QUOTE OF MIDWESTERN ELECTRIC, INC FOR INSTALLATION OF THE
DOWNTOWN STREET LIGHTING REPLACEMENT FIXTURES
IN THE AMOUNT OF SIXTEEN THOUSAND TWO HUNDRED DOLLARS
AND 00/100 CENTS (\$16,200.00)**

Whereas, The Redevelopment Commission of the Town of Highland, Indiana ("The Redevelopment Commission") is authorized to undertake redevelopment activities under IC 36-7-14 (the "Act") and more specifically Section 39 for which public money may be spent and private property may be acquired; and

Whereas, Redevelopment activities include performing all acts incident to the statutory powers and duties of a Redevelopment Commission; and

Whereas, The Redevelopment Commission is authorized to negotiate and enter into contracts pursuant to the Act; and

Whereas, The Redevelopment Commission has accepted a quote submitted by Chicago Lightworks for the Downtown Street Lighting Replacement Project fixtures; and

Whereas, Midwestern Electric, Inc. has submitted a quote in the amount of Sixteen Thousand Two Hundred Dollars and 00/100 Cents (\$16,200.00) to provide installation services related to the Downtown Street Lighting Replacement Project; and

Whereas, the Midwestern Electric, Inc. quote is more than \$15,000.00, the amount which may be approved by the Redevelopment Director without prior authorization from the Highland Redevelopment Commission; and

Whereas, there are sufficient and available appropriations balances on hand to support the payments under the agreement, pursuant to IC 36-7-14 (the "Act") and more specifically Section 39; and

Whereas, the Town of Highland, through its Redevelopment Commission, now desires to accept the recommendation of the Redevelopment Director and accept the quote for the Installation of the Replacement Fixtures as a component of the Downtown Street Lighting Replacement Project.

NOW, THEREFORE, BE IT RESOLVED by the Highland Redevelopment Commission of the Town of Highland, Lake County, Indiana as follows:

1. That it is in the best interest of the Town to accept the quote from Midwestern Electric, Inc. in the amount of \$16,200.00.

2. Further, the Redevelopment Director is hereby authorized to execute the agreement and all documents necessary to implement the project.
3. This resolution shall be in full force and effect after its passage and adoption by the Redevelopment Commission.

DULY PASSED AND RESOLVED by the Redevelopment Commission of the Town of Highland, Lake County, Indiana, this 15th day of December, 2020 having passed by a vote of 5 in favor and 0 opposed.

REDEVELOPMENT COMMISSION of the
TOWN OF HIGHLAND, INDIANA

By: 
Cyril Huerter, President

ATTEST:

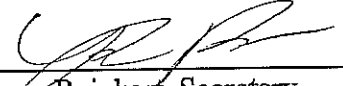
By: 
Renee Reinhart, Secretary
Town of Highland, Indiana Redevelopment Commission

December 16, 2020
Dated

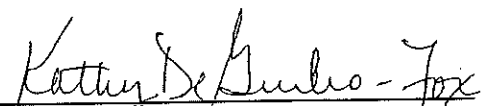
By: 
Kathy DeGulio-Fox, Redevelopment Director
Town of Highland Department of Redevelopment

December 16, 2020
Dated

Resolution 2020-31_Adopted 12-15-2020

GL Number Invoice Line Desc Ref # Vendor Invoice Description Amount Check #

Fund 094 REDEVELOPMENT GENERAL

Dept 0000	RC LEGAL FEES	89739	ABRAHAMSON, REED & BLISE	RC LEGAL FEES	1,368.00	
094-0000-31001	GENERAL ENGINEERING SERVICES	89741	NIES ENGINEERING, INC.	GENERAL ENGINEERING SERVICES	2,164.44	
094-0000-31003	LEGAL AD- 11/2 & 11/9	89744	THE TIMES OF NW INDIANA	LEGAL AD- 11/2 & 11/9	41.68	
094-0000-34023	HEALTH INS	89692	TOWN OF HIGHLAND INS FUND	(V NOVEMBER 2020 HEALTH/LIFE INS PREM	2,940.20	33300
094-0000-34043	LIFE INS	89692	TOWN OF HIGHLAND INS FUND	(V NOVEMBER 2020 HEALTH/LIFE INS PREM	15.88	33300
094-0000-35008	UTILITIES-2821 JEWETT	89742	NORHERN IN PUBLIC SERVICE	CUTILITIES- 2821 JEWETT	115.12	
094-0000-35008	UTILITIES-2811 JEWETT	89743	NORHERN IN PUBLIC SERVICE	CUTILITIES-2811 JEWETT	149.15	
094-0000-35008	STORM-8620 KENNEDY	89745	TOWN OF HIGHLAND UTILITIES	STORM- 8620 KENNEDY	40.67	
094-0000-35008	STORM-8618 KENNEDY	89746	TOWN OF HIGHLAND UTILITIES	STORM-8618 KENNEDY	40.67	
094-0000-35008	STORM-8612 KENNEDY	89747	TOWN OF HIGHLAND UTILITIES	STORM-8612 KENNEDY	10.14	
094-0000-35008	STORM-8610 KENNEDY	89748	TOWN OF HIGHLAND UTILITIES	STORM-8610 KENNEDY	10.14	
094-0000-35008	STORM-2605 CONDIT	89749	TOWN OF HIGHLAND UTILITIES	STORM-2605 CONDIT	10.14	
	Total For Dept 0000				6,906.23	
	Total For Fund 094 REDEVELOPMENT GENERAL				6,906.23	

Fund 096 REDEVELOPMENT CAPITAL

Dept 0000	FACADE REIMBURSEMENT-2940 HIGHWAY	16,934.49				
096-0000-34002	INTERIOR REIMBURSEMENT-2940 HIGHWAY	20,000.00				
	Total For Dept 0000	36,934.49				
	Total For Fund 096 REDEVELOPMENT CAPITAL	36,934.49				

Fund 098 DOWNTOWN REDEV DISTRICT ALLOC

Dept 0000	DR CONSTRUCTION INV 7657	89740	GRIMMER CONSTRUCTION	DR CONSTRUCTION INV 7657	177,965.41	
098-0000-44066					177,965.41	
	Total For Dept 0000				177,965.41	
	Total For Fund 098 DOWNTOWN REDEV DISTRICT ALLOC				177,965.41	

Fund 250 CREDIT ECON. DEV. INCOME TAX FUND

Dept 0000	SIGN PRODUCTION MATERIALS	89750	VIA MARKETING, INC	SIGN PRODUCTION MATERIALS	504.48	
250-0000-35010	ENGINEERING SERVICES	89751	WEAVER HOLDINGS, LLC	ENGINEERING SERVICES	2,362.50	
	Total For Dept 0000				2,866.98	
	Total For Fund 250 CREDIT ECON. DEV. INCOME TAX FUND				2,866.98	

12/09/2020 12:29 PM
User: DMJ
DB: Highland

INVOICE GL DISTRIBUTION REPORT FOR TOWN OF HIGHLAND
EXP CHECK RUN DATES 11/27/2020 - 12/16/2020
BOTH JOURNALIZED AND UNJOURNALIZED
BOTH OPEN AND PAID

GL Number	Invoice Line Desc	Ref #	Vendor	Invoice Description	Amount	Check #
-----------	-------------------	-------	--------	---------------------	--------	---------

Fund Totals:

Fund 094	REDEVELOPMENT GENERAL				6,906.23	
Fund 096	REDEVELOPMENT CAPITAL				36,934.49	
Fund 098	DOWNTOWN REDEV DISTRICT A				177,965.41	
Fund 250	CEDIT ECON. DEV. INCOME T				2,866.98	

224,673.11